

## DEKLARACJA WŁAŚCIWOŚCI UŻYTKOWYCH

### DoP 0194

dla systemu wklejanego fischer FIS VL (Łączniki metalowe do stosowania w betonie)

PL

1. <u>Niepowtarzalny kod identyfikacyjny typu wyrobu:</u>	<b>DoP 0194</b>		
2. <u>Zamierzone zastosowanie:</u>	<b>Mocowanie w betonie zarysowanym lub niezarysowanym. Zobacz załącznik, w szczególności aneksy B1- B8</b>		
3. <u>Producent:</u>	<b>fischerwerke GmbH &amp; Co. KG, Otto-Hahn-Straße 15, 79211 Denzlingen, Niemcy</b>		
4. <u>Upoważniony przedstawiciel:</u>	–		
5. <u>System(-y) oceny i weryfikacji stałości właściwości użytkowych:</u>	<b>1</b>		
6. <u>Europejski dokument oceny:</u>	<b>EAD 330499-01-0601</b>		
Europejska ocena techniczna:	<b>ETA- 10/0352; 2020-05-13</b>		
Jednostka ds. oceny technicznej:	<b>DIBt- Deutsches Institut für Bautechnik</b>		
Jednostka lub jednostki notyfikowane:	<b>1343 MPA Darmstadt / 2873 TU Darmstadt</b>		
7. <u>Deklarowane właściwości użytkowe:</u>			
<b>Wytrzymałość mechaniczna i stabilność osadzenia (BWR 1)</b>			
Nośność charakterystyczna na wrywanie (nośności statyczne i quasi-statyczne):	Nośność do uszkodzenia stali: Nośność na wrywanie i zniszczenie stożka betonu:	Aneksy C1, C2 Aneksy C3- C5	$\tau_{Rk,100}$ = NPD
	Nośność do wyrwania stożka betonu:	Aneksy C3	
	Odległość od krawędzi zapobiegająca pękaniu pod obciążeniem:	Aneksy C3	
	Solidność:	Aneksy C3- C5	
	Maksymalny moment dokręcania:	Aneksy B3, B4	
	Minimalne odstępy osiowe i krawędziowe:	Aneksy B3, B4	
Nośność charakterystyczna na ścinanie (nośności statyczne i quasi-statyczne):	Nośność do uszkodzenia stali: Nośność do uszkodzenia wyważenia: Nośność do zniszczenia krawędzi betonu:	Aneksy C1, C2 Aneksy C3 Aneksy C3	
Nośność charakterystyczna i przemieszczenia w warunkach sejsmicznych dla kategorii C1 i C2:	Nośność na wrywanie, zmiany, kategoria C1 Nośność na wrywanie, zmiany kategoria C2: Nośność na ścinanie, zmiany, kategoria C1: Nośność na ścinanie, zmiany, kategoria C1: Współczynnik szczeliny pierścieniowej	NPD NPD NPD NPD NPD	
Przemieszczenia pod obciążeniem krótko- i długoterminowym:	Przemieszczenia pod obciążeniem krótko- i długoterminowym:	Aneksy C6	
<b>Higiena, zdrowie i środowisko (BWR 3)</b>			
Treść, emisja i / lub uwalnianie substancji niebezpiecznych:	NPA		



8. Odpowiednia dokumentacja techniczna lub specjalna –  
dokumentacja techniczna:

Właściwości użytkowe określonego powyżej wyrobu są zgodne z zestawem deklarowanych właściwości użytkowych. Niniejsza deklaracja właściwości użytkowych wydana zostaje zgodnie z rozporządzeniem (UE) nr 305/2011 na wyłączną odpowiedzialność producenta określonego powyżej.

W imieniu producenta podpisał(-a):

Thilo Pregartner, Dr.-Ing.  
Tumlingen, 2020-05-26

Peter Schillinger, Dipl.-Ing.

Niniejsza Deklaracja Właściwości Użytkowych została przygotowana w różnych językach. W razie wątpliwości w interpretacji, wersja angielska jest zawsze miarodajna.

Załącznik zawiera dobrowolne i uzupełniające informacje w języku angielskim (neutralne językowo), a wykraczające poza wymagania prawne.

## Specific Part

### 1 Technical description of the product

The "fischer injection system FIS VL" is a bonded fastener consisting of a cartridge with injection mortar fischer FIS VL, fischer FIS VL High Speed or fischer FIS VL Low Speed and a steel element according to Annex A4.

The steel element is placed into a drilled hole filled with injection mortar and is anchored via the bond between metal part, injection mortar and concrete.

The product description is given in Annex A.

### 2 Specification of the intended use in accordance with the applicable European Assessment Document

The performances given in Section 3 are only valid if the anchor is used in compliance with the specifications and conditions given in Annex B.

The verifications and assessment methods on which this European Technical Assessment is based lead to the assumption of a working life of the anchor of at least 50 years. The indications given on the working life cannot be interpreted as a guarantee given by the producer, but are to be regarded only as a means for choosing the right products in relation to the expected economically reasonable working life of the works.

### 3 Performance of the product and references to the methods used for its assessment

#### 3.1 Mechanical resistance and stability (BWR 1)

Essential characteristic	Performance
Characteristic resistance to tension load (static and quasi-static loading)	See Annex B 3 and B 4, C 1 to C 5
Characteristic resistance to shear load (static and quasi-static loading)	See Annex C 1 to C 3
Displacements under short-term and long-term loading	See Annex C 6
Characteristic resistance and displacements for seismic performance categories C1 and C2	No performance assessed

#### 3.2 Hygiene, health and the environment (BWR 3)

Essential characteristic	Performance
Content, emission and/or release of dangerous substances	No performance assessed

**4 Assessment and verification of constancy of performance (AVCP) system applied, with reference to its legal base**

In accordance with the European Assessment Document EAD 330499-01-0601 the applicable European legal act is: [96/582/EC].

The system to be applied is: 1

# Installation conditions part 1

## fischer anchor rod

### Pre-positioned installation

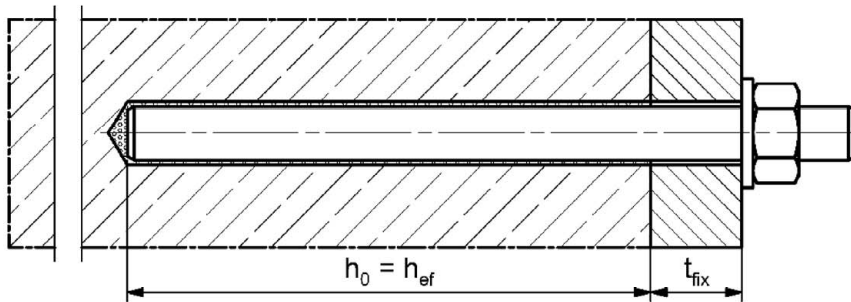

### Push through installation (annular gap filled with mortar)

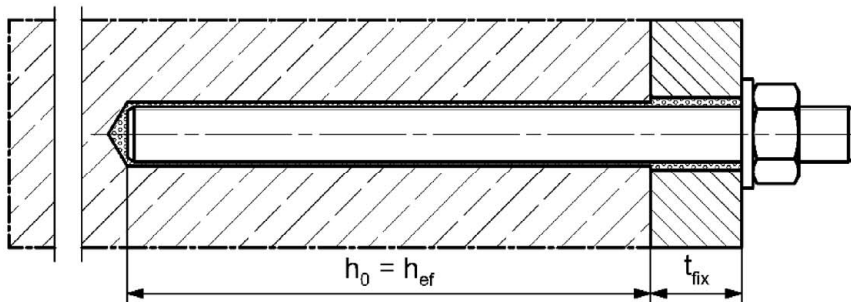

### Pre-positioned or push through installation with subsequently injected fischer filling disc (annular gap filled with mortar)

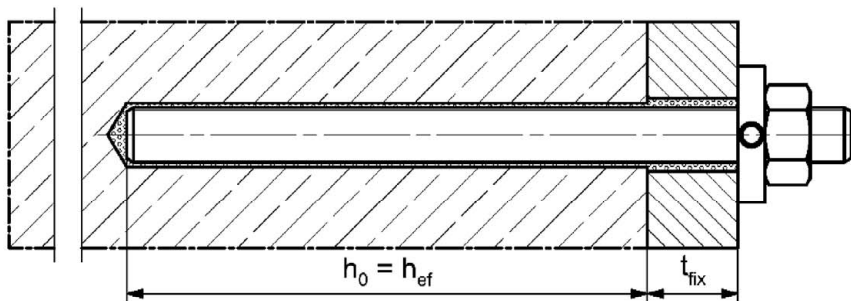

Figures not to scale

$h_0$  = drill hole depth

$h_{ef}$  = effective embedment depth

$t_{fix}$  = thickness of fixture

fischer injection system FIS VL

**Product description**  
Installation conditions part 1

**Annex A 1**

Appendix 3/ 21

## Installation conditions part 2

### fischer internal threaded anchor RG MI

#### Pre-positioned installation

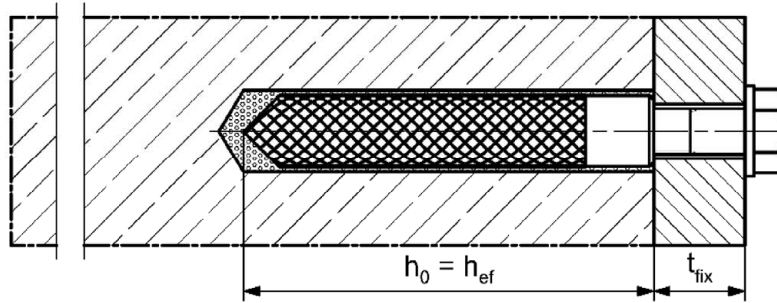

#### Pre-positioned installation with subsequently injected fischer filling disc (annular gap filled with mortar)

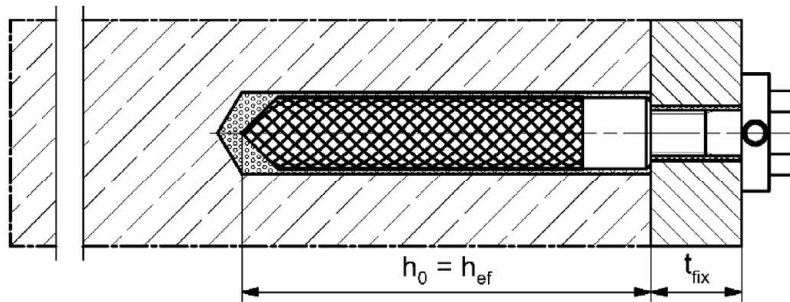

Figures not to scale

$h_0$  = drill hole depth

$h_{ef}$  = effective embedment depth

$t_{fix}$  = thickness of fixture

fischer injection system FIS VL

**Product description**  
Installation conditions part 2

**Annex A 2**

Appendix 4/ 21

## Overview system components part 1

**Injection cartridge (shuttle cartridge) with sealing cap; Sizes: 350 ml, 360 ml, 390 ml, 550 ml, 1100 ml, 1500 ml**

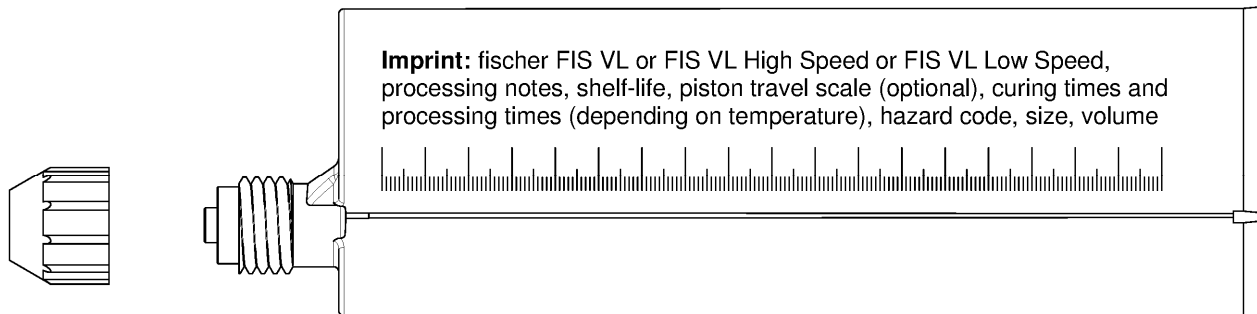

**Injection cartridge (coaxial cartridge) with sealing cap; Sizes: 100 ml, 150 ml, 300 ml, 380 ml, 400 ml, 410 ml**

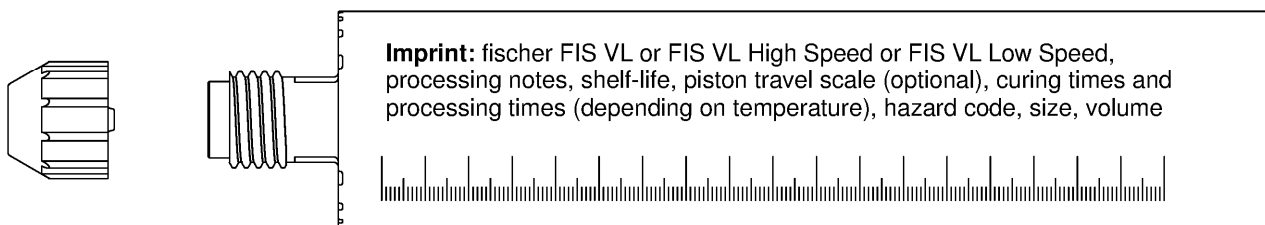

**Static mixer FIS MR Plus**

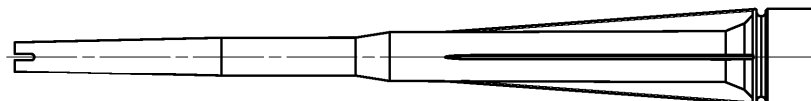

**Injection adapter and Extension tube for static mixer**

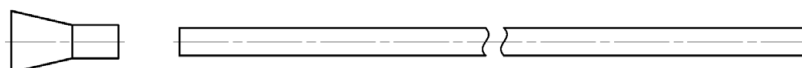

**Cleaning brush BS**



**Blow-out pump AB-G or ABP**



Figures not to scale

fischer injection system FIS VL

**Product description**

Overview system components part 1;  
cartridges / static mixer / accessories

**Annex A 3**

Appendix 5/ 21

## Overview system components part 2

### fischer anchor rod

Size: M6, M8, M10, M12, M16, M20, M24, M27, M30

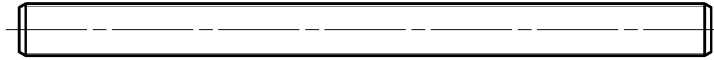

### fischer internal threaded anchor RG MI

Size: M8, M10, M12, M16, M20



### Screw / threaded rod / washer / hexagon nut

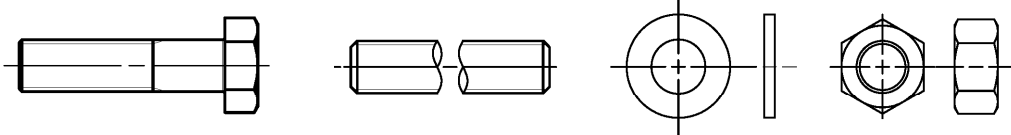

### fischer filling disc with injection adapter

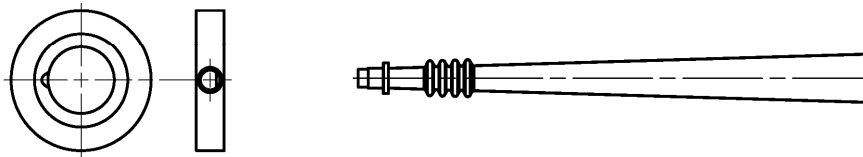

Figures not to scale

fischer injection system FIS VL

#### Product description

Overview system components part 2;  
steel components

**Annex A 4**

Appendix 6/ 21



**Table A5.1: Materials**

Part	Designation	Material		
1	Injection cartridge	Mortar, hardener, filler		
	Steel grade	Steel	Stainless steel R	High corrosion resistant steel HCR
		zinc plated	acc. to EN 10088-1:2014 Corrosion resistance class CRC III acc. to EN 1993-1-4:2015	acc. to EN 10088-1:2014 Corrosion resistance class CRC V acc. to EN 1993-1-4:2015
2	Anchor rod	Property class 4.8, 5.8 or 8.8; EN ISO 898-1:2013 zinc plated $\geq 5 \mu\text{m}$ , ISO 4042:2018/Zn5/An(A2K) or hot dip galvanised $\geq 40 \mu\text{m}$ EN ISO 10684:2004 $f_{uk} \leq 1000 \text{ N/mm}^2$ $A_5 > 8\%$ fracture elongation	Property class 50, 70 or 80 EN ISO 3506-1:2009 1.4401; 1.4404; 1.4578; 1.4571; 1.4439; 1.4362; 1.4062, 1.4662, 1.4462; EN 10088-1:2014 $f_{uk} \leq 1000 \text{ N/mm}^2$ $A_5 > 8\%$ fracture elongation	Property class 50 or 80 EN ISO 3506-1:2009 or property class 70 with $f_{yk} = 560 \text{ N/mm}^2$ 1.4565; 1.4529; EN 10088-1:2014 $f_{uk} \leq 1000 \text{ N/mm}^2$ $A_5 > 8\%$ fracture elongation
3	Washer ISO 7089:2000	zinc plated $\geq 5 \mu\text{m}$ , ISO 4042:2018/Zn5/An(A2K) or hotdip galvanised $\geq 40 \mu\text{m}$ EN ISO 10684:2004	1.4401; 1.4404; 1.4578; 1.4571; 1.4439; 1.4362; EN 10088-1:2014	1.4565; 1.4529; EN 10088-1:2014
4	Hexagon nut	Property class 4, 5 or 8; EN ISO 898-2:2012 zinc plated $\geq 5 \mu\text{m}$ , ISO 4042:2018/Zn5/An(A2K) or hot dip galvanised $\geq 40 \mu\text{m}$ EN ISO 10684:2004	Property class 50, 70 or 80 EN ISO 3506-1:2009 1.4401; 1.4404; 1.4578; 1.4571; 1.4439; 1.4362; EN 10088-1:2014	Property class 50, 70 or 80 EN ISO 3506-1:2009 1.4565; 1.4529 EN 10088-1:2014
5	fischer internal threaded anchor RG MI	Property class 5.8 ISO 898-1:2013 zinc plated $\geq 5 \mu\text{m}$ , ISO 4042:2018/Zn5/An(A2K)	Property class 70 EN ISO 3506-1:2009 1.4401; 1.4404; 1.4578; 1.4571; 1.4439; 1.4362; EN 10088-1:2014	Property class 70 EN ISO 3506-1:2009 1.4565; 1.4529; EN 10088-1:2014
6	Commercial standard screw or threaded rod for fischer internal threaded anchor RG MI	Property class 5.8 or 8.8; EN ISO 898-1:2013 zinc plated $\geq 5 \mu\text{m}$ , ISO 4042:2018/Zn5/An(A2K) $A_5 > 8\%$ fracture elongation	Property class 70 EN ISO 3506-1:2009 1.4401; 1.4404; 1.4578; 1.4571; 1.4439; 1.4362; EN 10088-1:2014 $A_5 > 8\%$ fracture elongation	Property class 70 EN ISO 3506-1:2009 1.4565; 1.4529; EN 10088-1:2014 $A_5 > 8\%$ fracture elongation
7	fischer filling disc similar to DIN 6319-G	zinc plated $\geq 5 \mu\text{m}$ , ISO 4042:2018/Zn5/An(A2K) or hot dip galvanised $\geq 40 \mu\text{m}$ EN ISO 10684:2004	1.4401; 1.4404; 1.4578; 1.4571; 1.4439; 1.4362; EN 10088-1:2014	1.4565; 1.4529; EN 10088-1:2014





fischer injection system FIS VL

**Product description**  
Materials**Annex A 5**

Appendix 7/ 21

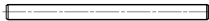
# Specifications of intended use (part 1)

**Table B1.1:** Overview use and performance categories

Anchorages subject to		<b>FIS VL with ...</b>			
		Anchor rod 	fischer internal threaded anchor RG MI 		
Hammer drilling with standard drill bit 		all sizes			
Hammer drilling with hollow drill bit (fischer FHD, Heller "Duster Expert"; Bosch „Speed Clean“; Hilti "TE-CD, TE-YD", DreBo „D-Plus“, DreBo „D-Max“) 		Nominal drill bit diameter ( $d_0$ ) 12 mm to 35 mm			
Static and quasi static load, in	uncracked concrete	all sizes	Tables: C1.1 C3.1 C4.1 C6.1	all sizes	Tables: C2.1 C3.1 C5.1 C6.2
	cracked concrete	M10 bis M20		_2)	
Use category	I1 dry or wet concrete	all sizes			
	I2 water filled hole <sup>1)</sup>	M 12 to M 30	M 8 bis M 20		
Installation direction		D3 (downward and horizontal and upwards (e.g. overhead) installation)			
Installation temperature		$T_{i,min} = -10\text{ °C}$ to $T_{i,max} = +40\text{ °C}$			
In-service temperature	Temperature range I	-40 °C to +80 °C	(max. short term temperature +80 °C; max. long term temperature +50 °C)		
	Temperature range II	-40 °C to +120 °C	(max. short term temperature +120 °C; max. long term temperature +72 °C)		

<sup>1)</sup> Only with coaxial cartridges: 380ml, 400 ml, 410 ml

<sup>2)</sup> No performance assessed

fischer injection system FIS VL

**Intended use**  
Specifications (part 1)

**Annex B 1**

Appendix 8/ 21

## Specifications of intended use (part 2)

### Base materials:

- Compacted reinforced or unreinforced normal weight concrete without fibres of strength classes C20/25 to C50/60 according to EN 206:2013+A1:2016

### Use conditions (Environmental conditions):

- Structures subject to dry internal conditions (zinc coated steel, stainless steel or high corrosion resistant steel).
- For all other conditions according to EN1993-1-4:2015 corresponding to corrosion resistance classes to Annex A 5 table A5.1.

### Design:

- Anchorages have to be designed by a responsible engineer with experience of concrete anchor design.
- Verifiable calculation notes and drawings are to be prepared taking account of the loads to be anchored. The position of the anchor is indicated on the design drawings (e. g. position of the anchor relative to reinforcement or to supports, etc.).
- Anchorages are designed in accordance with:  
EN 1992-4:2018 and EOTA Technical Report TR 055, Edition February 2018.

### Installation:

- Anchor installation is to be carried out by appropriately qualified personnel and under the supervision of the person responsible for technical matters of the site
- In case of aborted hole: The hole shall be filled with mortar
- Anchorage depth should be marked and adhered to on installation
- Overhead installation is allowed

fischer injection system FIS VL

**Intended use**  
Specifications (part 2)

**Annex B 2**

Appendix 9/ 21

**Table B3.1: Installation parameters for anchor rods**

Anchor rods		Thread	M6	M8	M10	M12	M16	M20	M24	M27	M30	
Width across flats	SW	[mm]	10	13	17	19	24	30	36	41	46	
Nominal drill hole diameter	$d_0$		8	10	12	14	18	24	28	30	35	
Drill hole depth	$h_0$		$h_0 = h_{ef}$									
Effective embedment depth	$h_{ef, min}$		50	60	60	70	80	90	96	108	120	
	$h_{ef, max}$		72	160	200	240	320	400	480	540	600	
Minimum spacing and minimum edge distance	$s_{min} = c_{min}$		40	40	45	55	65	85	105	125	140	
Diameter of the clearance hole of the fixture	pre-positioned installation $d_f$		7	9	12	14	18	22	26	30	33	
	push through installation $d_f$		9	12	14	16	20	26	30	33	40	
Minimum thickness of concrete member	$h_{min}$		$h_{ef} + 30 (\geq 100)$					$h_{ef} + 2d_0$				
Maximum installation torque	$\max T_{inst}$		[Nm]	5	10	20	40	60	120	150	200	300

**fischer anchor rod**

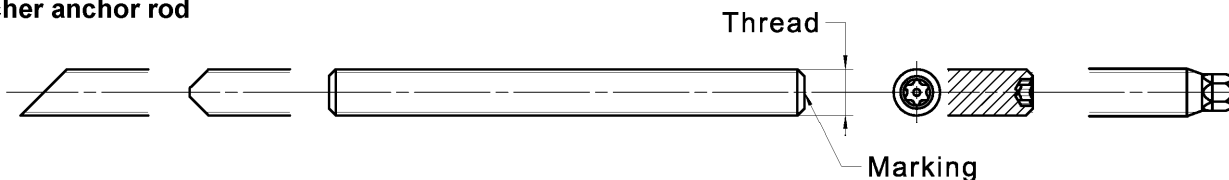

**Marking (on random place) fischer anchor rod:**

Steel zinc plated PC <sup>1)</sup> 8.8	• or +	Steel hot-dip PC <sup>1)</sup> 8.8	•
High corrosion resistant steel HCR PC <sup>1)</sup> 50	•	High corrosion resistant steel HCR PC <sup>1)</sup> 70	-
High corrosion resistant steel HCR PC <sup>1)</sup> 80	(	Stainless steel R property class 50	~
Stainless steel R property class 80	*		
Alternatively: Colour coding according to DIN 976-1:2016		1) PC = property class	

**Installation conditions:**

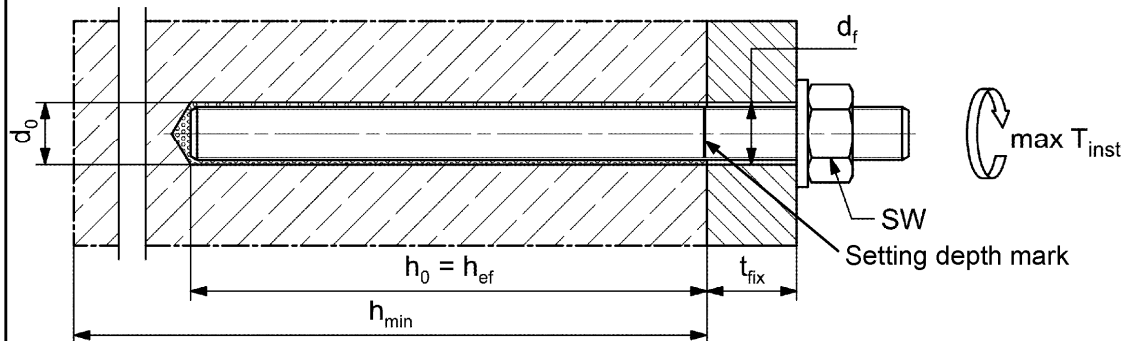

**Commercial standard threaded rods, washers and hexagon nuts may also be used if the following requirements are fulfilled**

- Materials, dimensions and mechanical properties according to Annex A 5, Table A5.1
- Inspection certificate 3.1 according to EN 10204:2004, the documents have to be stored
- Setting depth is marked

Figures not to scale

fischer injection system FIS VL

**Intended use**  
Installation parameters anchor rods

**Annex B 3**

Appendix 10/ 21

**Table B4.1:** Installation parameters for **fischer internal threaded anchors RG MI**

Internal threaded anchors RG MI		Thread	M8	M10	M12	M16	M20
Diameter of anchor	$d_{nom} = d_H$	[mm]	12	16	18	22	28
Nominal drill hole diameter	$d_0$		14	18	20	24	32
Drill hole depth	$h_0$		$h_0 = h_{ef} = L_H$				
Effective embedment depth ( $h_{ef} = L_H$ )	$h_{ef}$		90	90	125	160	200
Minimum spacing and minimum edge distance	$s_{min} = c_{min}$		55	65	75	95	125
Diameter of clearance hole in the fixture	$d_f$		9	12	14	18	22
Minimum thickness of concrete member	$h_{min}$		120	125	165	205	260
Maximum screw-in depth	$l_{E,max}$		18	23	26	35	45
Minimum screw-in depth	$l_{E,min}$		8	10	12	16	20
Maximum installation torque	$\max T_{inst}$		[Nm]	10	20	40	80

**fischer internal threaded anchor RG MI**

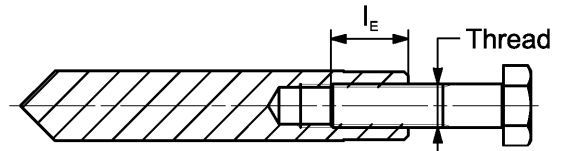
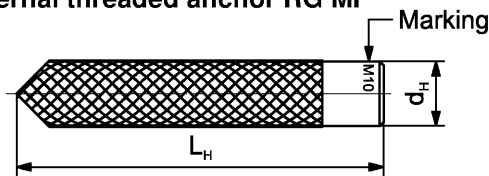

**Marking:** Anchor size e. g.: **M10**  
 Stainless steel → additional **R**; e.g.: **M10 R**  
 High corrosion resistant steel → additional **HCR**; e.g.: **M10 HCR**

Retaining bolt or threaded rods (including nut and washer) must comply with the appropriate material and strength class of Annex A 5, Table A5.1

**Installation conditions:**

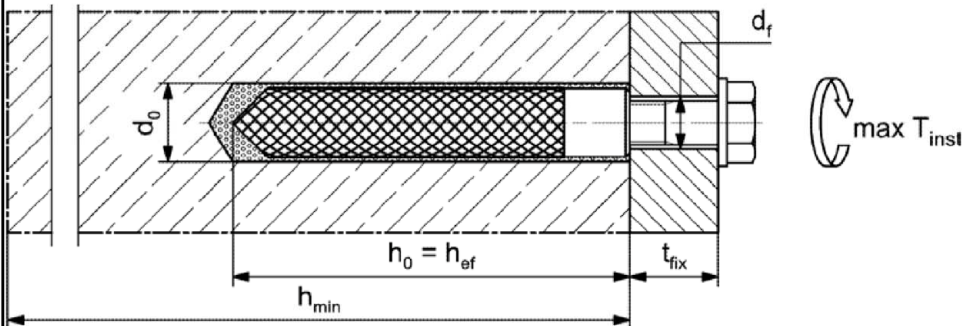

Figures not to scale

fischer injection system FIS VL

**Intended use**  
 Installation parameters internal threaded anchors RG MI

**Annex B 4**

Appendix 11/ 21

**Table B5.1:** Parameters of the **cleaning brush BS** (steel brush with steel bristles)

The size of the cleaning brush refers to the drill hole diameter

Nominal drill hole diameter	$d_0$	[mm]	8	10	12	14	16	18	20	24	25	28	30	35
Steel brush diameter BS	$d_b$		9	11	14	16	20		25	26	27	30	40	



**Table B5.2** **Maximum processing time** of the mortar and **minimum curing time** (During the curing time of the mortar the concrete temperature may not fall below the listed minimum temperature)

Temperature at anchoring base [°C]	Maximum processing time $t_{work}$			Minimum curing time $t_{cure}$ <sup>1)</sup>		
	FIS VL High Speed	FIS VL	FIS VL Low Speed	FIS VL High Speed	FIS VL	FIS VL Low Speed
-10 to -5 <sup>2)</sup>	-	-	-	12 h	-	-
> -5 to 0 <sup>2)</sup>	5 min	-	-	3 h	24 h	-
> 0 to 5 <sup>2)</sup>	5 min	13 min	-	3 h	3 h	6 h
> 5 to 10	3 min	9 min	20 min	50 min	90 min	3 h
> 10 to 20	1 min	5 min	10 min	30 min	60 min	2 h
> 20 to 30	-	4 min	6 min	-	45 min	60 min
> 30 to 40	-	2 min	4 min	-	35 min	30 min

<sup>1)</sup> In wet concrete or water filled holes the curing times must be doubled

<sup>2)</sup> Minimal cartridge temperature +5°C

fischer injection system FIS VL

**Intended use**

Cleaning brush (steel brush)  
Processing time and curing time

**Annex B 5**

Appendix 12/ 21

# Installation instructions part 1

## Drilling and cleaning the hole (hammer drilling with standard drill bit)

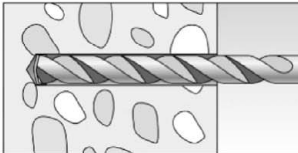
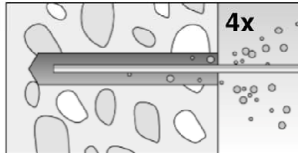
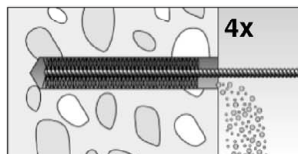
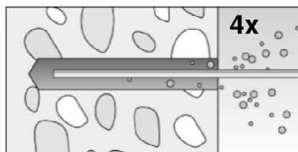
1		<p>Drill the hole. Nominal drill hole diameter <math>d_0</math> and drill hole depth <math>h_0</math> see <b>tables B3.1, B4.1</b></p>
2		<p>Clean the drill hole: For <math>h_{ef} \leq 12d</math> and <math>d_0 &lt; 18</math> mm blow out the hole four times by hand</p>
3		<p>Brush the drill hole four times. For deep holes use an extension. Corresponding brushes see <b>table B5.1</b></p>
4		<p>Clean the drill hole: For <math>h_{ef} \leq 12d</math> and <math>d_0 &lt; 18</math> mm blow out the hole four times by hand</p>
		<p>For <math>h_{ef} &gt; 12d</math> and / or <math>d_0 \geq 18</math> mm blow out the hole four times with oil-free compressed air (<math>p \geq 6</math> bar)</p>

Go to step 5

## Drilling and cleaning the hole (hammer drilling with hollow drill bit)

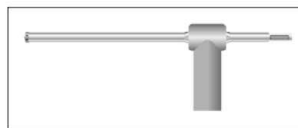
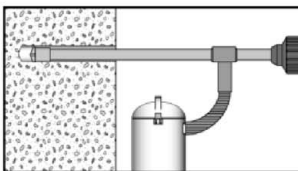
1		<p>Check a suitable hollow drill (see <b>table B1.1</b>) for correct operation of the dust extraction</p>
2		<p>Use a suitable dust extraction system, e. g. fischer FVC 35 M or a comparable dust extraction system with equivalent performance data</p> <p>Drill the hole with hollow drill bit. The dust extraction system has to extract the drill dust nonstop during the drilling process and must be adjusted to maximum power. Nominal drill hole diameter <math>d_0</math> and drill hole depth <math>h_0</math> see <b>tables B3.1, B4.1</b></p>

Go to step 5

fischer injection system FIS VL



**Intended use**  
Installation instructions part 1

**Annex B 6**

Appendix 13/ 21

## Installation instructions part 2

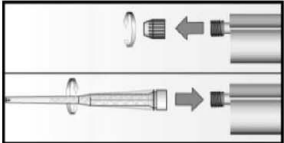
### Preparing the cartridge

5		Remove the sealing cap Screw on the static mixer (the spiral in the static mixer must be clearly visible)
6		Place the cartridge into the dispenser
7		Extrude approximately 10 cm of material out until the resin is evenly grey in colour. Do not use mortar that is not uniformly grey

Go to step 8

### Injection of the mortar

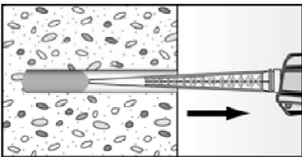
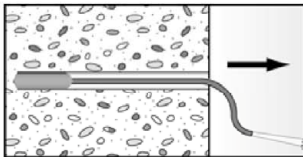
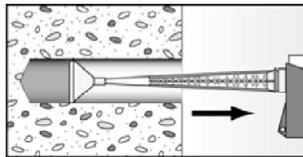
8	 <p>Fill approximately 2/3 of the drill hole with mortar. Always begin from the bottom of the hole and avoid bubbles</p>	 <p>For drill hole depth <math>\geq 150</math> mm use an extension tube</p>	 <p>For overhead installation, deep holes (<math>h_0 &gt; 250</math> mm) or drill hole diameter (<math>d_0 \geq 40</math> mm) use an injection adapter</p>
---	---	--	---

Go to step 9

fischer injection system FIS VL

**Intended use**  
Installation instructions part 2



**Annex B 7**

Appendix 14/ 21

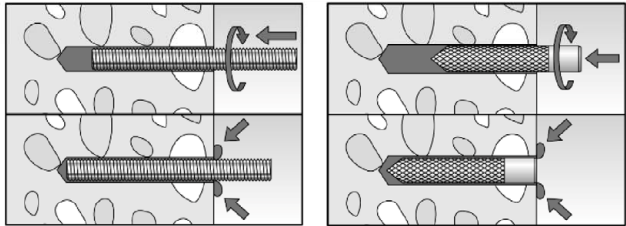
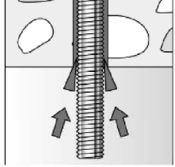
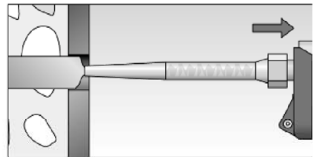

### Installation instructions part 3

#### Installation of anchor rods or fischer internal threaded anchors RG MI

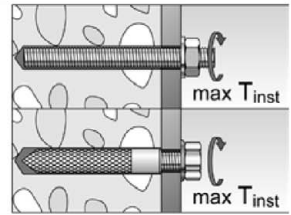
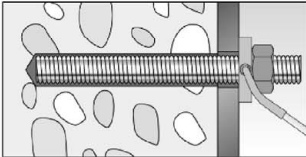
9		<p>Only use clean and oil-free metal parts. Mark the setting depth of the metal part. Push the anchor rod or fischer internal threaded RG MI anchor down to the bottom of the hole, turning it slightly while doing so. After inserting the metal parts, excess mortar must be emerged around the anchor element.</p>
	 <p>For overhead installations support the metal part with wedges (e. g. fischer centering wedges) or fischer overhead clips.</p>	 <p>For push through installation fill the annular gap with mortar</p>
10	 <p>Wait for the specified curing time <math>t_{cure}</math> see <b>table B5.2</b></p>	<p>11</p>  <p>Mounting the fixture max <math>T_{inst}</math> see <b>tables B3.1 and B4.1</b></p>
Option		<p>After the minimum curing time is reached, the gap between metal part and fixture (annular clearance) may be filled with mortar via the fischer filling disc. Compressive strength <math>\geq 50 \text{ N/mm}^2</math> (e.g. fischer injection mortars FIS HB, FIS SB, FIS V, FIS EM Plus). ATTENTION: Using fischer filling disc reduces <math>t_{fix}</math> (usable length of the anchor)</p>

fischer injection system FIS VL

**Intended use**  
Installation instructions part 3

**Annex B 8**

Appendix 15/ 21

**Table C1.1: Characteristic values for under tension / shear load of fischer anchor rods and standard threaded rods**

Anchor rod / standard threaded rod			M6	M8	M10	M12	M16	M20	M24	M27	M30		
<b>Bearing capacity under tension load, steel failure <sup>3)</sup></b>													
Characteristic resistance $N_{Rk,s}$	Steel zinc plated	Property class	4.8	[kN]	8	15(13)	23(21)	33	63	98	141	184	224
			5.8		10	19(17)	29(27)	43	79	123	177	230	281
			8.8		16	29(27)	47(43)	68	126	196	282	368	449
	Stainless steel R and high corrosion resistant steel HCR		50		10	19	29	43	79	123	177	230	281
			70		14	26	41	59	110	172	247	322	393
			80		16	30	47	68	126	196	282	368	449
<b>Partial factors <sup>1)</sup></b>													
Partial factor $\gamma_{Ms,N}$	Steel zinc plated	Property class	4.8	[-]	1,50								
			5.8		1,50								
			8.8		1,50								
	Stainless steel R and high corrosion resistant steel HCR		50		2,86								
			70		1,50 <sup>2)</sup> / 1,87								
			80		1,60								
<b>Bearing capacity under shear load, steel failure <sup>3)</sup></b>													
<b>without lever arm</b>													
Characteristic resistance $V_{Rk,s}^0$	Steel zinc plated	Property class	4.8	[kN]	4	9(8)	14(13)	20	38	59	85	110	135
			5.8		6	11(10)	17(16)	25	47	74	106	138	168
			8.8		8	15(13)	23(21)	34	63	98	141	184	225
	Stainless steel R and high corrosion resistant steel HCR		50		5	9	15	21	39	61	89	115	141
			70		7	13	20	30	55	86	124	161	197
			80		8	15	23	34	63	98	141	184	225
Ductility factor		$k_7$	[-]	1,0									
<b>with lever arm</b>													
Charact. resistance $M_{Rk,s}^0$	Steel zinc plated	Property class	4.8	[Nm]	6	15(13)	30(27)	52	133	259	448	665	899
			5.8		7	19(16)	37(33)	65	166	324	560	833	1123
			8.8		12	30(26)	60(53)	105	266	519	896	1333	1797
	Stainless steel R and high corrosion resistant steel HCR		50		7	19	37	65	166	324	560	833	1123
			70		10	26	52	92	232	454	784	1167	1573
			80		12	30	60	105	266	519	896	1333	1797
<b>Partial factors <sup>1)</sup></b>													
Partial factor $\gamma_{Ms,V}$	Steel zinc plated	Property class	4.8	[-]	1.25								
			5.8		1.25								
			8.8		1.25								
	Stainless steel R and high corrosion resistant steel HCR		50		2.38								
			70		1.25 <sup>2)</sup> / 1.56								
			80		1.33								

<sup>1)</sup> In absence of other national regulations

<sup>2)</sup> Only admissible for high corrosion resistant steel HCR, with  $f_{yk} / f_{uk} \geq 0,8$  and  $A_s > 12 \%$  (e.g. fischer anchor rods)

<sup>3)</sup> Values in brackets are valid for undersized threaded rods with smaller stress area  $A_s$  for hot dip galvanised standard threaded rods according to EN ISO 10684:2004+AC:2009

fischer injection system FIS VL

**Performances**

Characteristic values for steel failure under tension / shear load of fischer anchor rods and standard threaded rods

**Annex C 1**

Appendix 16/ 21

**Table C2.1: Characteristic values for steel failure under tension / shear load of fischer internal threaded anchors RG MI**

fischer internal threaded anchors RG MI				M8	M10	M12	M16	M20	
<b>Bearing capacity under tension load, steel failure</b>									
Charact. resistance with screw	$N_{Rk,s}$	Property class	5.8	[kN]	19	29	43	79	123
			8.8		29	47	68	108	179
		Property class 70	R		26	41	59	110	172
			HCR		26	41	59	110	172
<b>Partial factors<sup>1)</sup></b>									
Partial factors	$\gamma_{Ms,N}$	Property class	5.8	[-]	1,50				
			8.8		1,50				
		Property class 70	R		1,87				
			HCR		1,87				
<b>Bearing capacity under shear load, steel failure</b>									
<b>Without lever arm</b>									
Charact. resistance with screw	$V^0_{Rk,s}$	Property class	5.8	[kN]	9,2	14,5	21,1	39,2	62,0
			8.8		14,6	23,2	33,7	54,0	90,0
		Property class 70	R		12,8	20,3	29,5	54,8	86,0
			HCR		12,8	20,3	29,5	54,8	86,0
Ductility factor		$k_7$	[-]	1,0					
<b>With lever arm</b>									
Charact. resistance with screw	$M^0_{Rk,s}$	Property class	5.8	[Nm]	20	39	68	173	337
			8.8		30	60	105	266	519
		Property class 70	R		26	52	92	232	454
			HCR		26	52	92	232	454
<b>Partial factors<sup>1)</sup></b>									
Partial factors	$\gamma_{Ms,V}$	Property class	5.8	[-]	1,25				
			8.8		1,25				
		Property class 70	R		1,56				
			HCR		1,56				

<sup>1)</sup> In absence of other national regulations

fischer injection system FIS VL

**Performances**

Characteristic values for steel failure under tension / shear load of fischer internal threaded anchor RG MI

**Annex C 2**

<b>Table C3.1: Characteristic values for concrete failure under tension / shear load</b>												
<b>Size</b>			<b>All sizes</b>									
<b>Tension load</b>												
Installation factor			$\gamma_{inst}$	[-]		See annex C 4 to C 5						
<b>Factors for the compressive strength of concrete &gt; C20/25</b>												
Increasing factor for $\tau_{Rk}$		C25/30		$\Psi_c$	[-]	1,05						
		C30/37				1,10						
		C35/45				1,15						
		C40/50				1,19						
		C45/55				1,22						
		C50/60				1,26						
<b>Splitting failure</b>												
Edge distance		$h / h_{ef} \geq 2,0$		$C_{cr,sp}$	[mm]	1,0 $h_{ef}$						
		$2,0 > h / h_{ef} > 1,3$				4,6 $h_{ef}$ - 1,8 h						
		$h / h_{ef} \leq 1,3$				2,26 $h_{ef}$						
Spacing		$S_{cr,sp}$		2 $C_{cr,sp}$								
<b>Concrete cone failure</b>												
Uncracked concrete		$k_{ucr,N}$		[-]	11,0							
Cracked concrete		$k_{cr,N}$			7,7							
Edge distance		$C_{cr,N}$		[mm]	1,5 $h_{ef}$							
Spacing		$S_{cr,N}$			2 $C_{cr,N}$							
<b>Factors for sustained tension load</b>												
Temperature range			[-]		50 °C / 80 °C			72 °C / 120 °C				
Factor			$\Psi_{sus}^0$		[-]		0,74		0,87			
<b>Shear load</b>												
Installation factor			$\gamma_{inst}$		[-]		1,2					
<b>Concrete pry-out failure</b>												
Factor for pry-out failure			$k_8$		[-]		2,0					
<b>Concrete edge failure</b>												
Effective length of fastener in shear loading			$l_f$		[mm]		for $d_{nom} \leq 24$ mm: min ( $h_{ef}$ ; 12 $d_{nom}$ ) for $d_{nom} > 24$ mm: min ( $h_{ef}$ ; 8 $d_{nom}$ ; 300 mm)					
<b>Calculation diameters</b>												
Size			M6	M8	M10	M12	M16	M20	M24	M27	M30	
fischer anchor rods and standard threaded rods		$d_{nom}$		6	8	10	12	16	20	24	27	30
fischer internal threaded anchors RG MI		$d_{nom}$		- <sup>1)</sup>	12	16	18	22	28	- <sup>1)</sup>	- <sup>1)</sup>	- <sup>1)</sup>
<sup>1)</sup> Anchor type not part of the assessment												
fischer injection system FIS VL								<b>Annex C 3</b> Appendix 18/ 21				
<b>Performances</b> Characteristic values for concrete failure under tension / shear load												

**Table C4.1: Characteristic values for combined pull-out and concrete failure for fischer anchor rods and standard threaded rods in hammer drilled holes; uncracked or cracked concrete**

Anchor rod / standard threaded rod		M6	M8	M10	M12	M16	M20	M24	M27	M30		
<b>Combined pullout and concrete cone failure</b>												
Calculation diameter	d	[mm]	6	8	10	12	16	20	24	27	30	
<b>Uncracked concrete</b>												
<b>Characteristic bond resistance in uncracked concrete C20/25</b>												
Hammer-drilling with standard drill bit or hollow drill bit (dry or wet concrete)												
Temperature range	I: 50 °C / 80 °C	$\tau_{Rk,ucr}$	[N/mm <sup>2</sup> ]	9,0	11,0	11,0	11,0	10,0	9,5	9,0	8,5	8,5
	II: 72 °C / 120 °C			6,5	9,5	9,5	9,0	8,5	8,0	7,5	7,0	7,0
Hammer-drilling with standard drill bit or hollow drill bit (water filled hole) <sup>1)</sup>												
Temperature range	I: 50 °C / 80 °C	$\tau_{Rk,ucr}$	[N/mm <sup>2</sup> ]	-2)	-2)	-2)	9,5	8,5	8,0	7,5	7,0	7,0
	II: 72 °C / 120 °C			-2)	-2)	-2)	7,5	7,0	6,5	6,0	6,0	6,0
<b>Installation factors</b>												
Dry or wet concrete	$\gamma_{inst}$	[-]	1,2									
Water filled hole			-2)	-2)	-2)	1,4 <sup>1)</sup>						
<b>Cracked concrete</b>												
<b>Characteristic bond resistance in cracked concrete C20/25</b>												
Hammer-drilling with standard drill bit or hollow drill bit (dry or wet concrete)												
Temperature range	I: 50 °C / 80 °C	$\tau_{Rk,cr}$	[N/mm <sup>2</sup> ]	-2)	-2)	6,0	6,0	6,0	5,5	-2)	-2)	-2)
	II: 72 °C / 120 °C			-2)	-2)	5,0	6,0	6,0	5,0	-2)	-2)	-2)
Hammer-drilling with standard drill bit or hollow drill bit (water filled hole) <sup>1)</sup>												
Temperature range	I: 50 °C / 80 °C	$\tau_{Rk,cr}$	[N/mm <sup>2</sup> ]	-2)	-2)	-2)	5,0	5,0	4,5	-2)	-2)	-2)
	II: 72 °C / 120 °C			-2)	-2)	-2)	4,0	4,0	4,0	-2)	-2)	-2)
<b>Installation factors</b>												
Dry or wet concrete	$\gamma_{inst}$	[-]	1,2									
Water filled hole			-2)	-2)	-2)	1,4 <sup>1)</sup>						

<sup>1)</sup> Only with coaxial cartridges: 380ml, 400 ml, 410 ml

<sup>2)</sup> No Performance assessed

fischer injection system FIS VL

**Performances**

Characteristic values for combined pull-out and concrete failure for fischer anchor rod and standard threaded rods

**Annex C 4**

Appendix 19/ 21

**Table C5.1: Characteristic values for combined pull-out and concrete failure for fischer internal threaded anchors RG MI in hammer drilled holes; uncracked concrete**

Internal threaded anchor RG MI			M8	M10	M12	M16	M20	
<b>Combined pullout and concrete cone failure</b>								
Calculation diameter	d	[mm]	12	16	18	22	28	
<b>Uncracked concrete</b>								
<b>Characteristic bond resistance in uncracked concrete C20/25</b>								
Hammer-drilling with standard drill bit or hollow drill bit (dry or wet concrete)								
Temperature range	I: 50 °C / 80 °C	$\tau_{Rk,ucr}$	[N/mm <sup>2</sup> ]	10,5	10,0	9,5	9,0	8,5
	II: 72 °C / 120 °C			9,0	8,0	8,0	7,5	7,0
Hammer-drilling with standard drill bit or hollow drill bit (water filled hole) <sup>1)</sup>								
Temperature range	I: 50 °C / 80 °C	$\tau_{Rk,ucr}$	[N/mm <sup>2</sup> ]	10,0	9,0	9,0	8,5	8,0
	II: 72 °C / 120 °C			7,5	6,5	6,5	6,0	6,0
<b>Installation factors</b>								
Dry or wet concrete	$\gamma_{inst}$	[-]	1,2					
Water filled hole			1,4 <sup>1)</sup>					

<sup>1)</sup> Only with coaxial cartridges: 380 ml, 400 ml, 410 ml

fischer injection system FIS VL

**Performances**

Characteristic values for combined pull-out and concrete failure for fischer internal threaded anchors RG MI

**Annex C 5**

Appendix 20/ 21

**Table C6.1: Displacements for anchor rods**

Anchor rod	M6	M8	M10	M12	M16	M20	M24	M27	M30	
<b>Displacement-Factors for tension load<sup>1)</sup></b>										
<b>Uncracked concrete; Temperature range I, II</b>										
$\delta_{N0}$ -Factor	[mm/(N/mm <sup>2</sup> )]	0,09	0,09	0,09	0,10	0,10	0,10	0,10	0,11	0,12
$\delta_{N\infty}$ -Factor		0,10	0,10	0,10	0,12	0,12	0,12	0,13	0,13	0,14
<b>Cracked concrete; Temperature range I, II</b>										
$\delta_{N0}$ -Factor	[mm/(N/mm <sup>2</sup> )]	- <sup>3)</sup>	- <sup>3)</sup>	0,12	0,12	0,13	0,13	- <sup>3)</sup>	- <sup>3)</sup>	- <sup>3)</sup>
$\delta_{N0}$ -Factor		- <sup>3)</sup>	- <sup>3)</sup>	0,27	0,30	0,30	0,30	- <sup>3)</sup>	- <sup>3)</sup>	- <sup>3)</sup>
<b>Displacement-Factors for shear load<sup>2)</sup></b>										
<b>Uncracked or cracked concrete; Temperature range I, II</b>										
$\delta_{V0}$ -Factor	[mm/kN]	0,11	0,11	0,11	0,10	0,10	0,09	0,09	0,08	0,07
$\delta_{V\infty}$ -Factor		0,12	0,12	0,12	0,11	0,11	0,10	0,10	0,09	0,09

1) Calculation of effective displacement:

$$\delta_{N0} = \delta_{N0\text{-Factor}} \cdot \tau_{Ed}$$

$$\delta_{N\infty} = \delta_{N\infty\text{-Factor}} \cdot \tau_{Ed}$$

( $\tau_{Ed}$ : Design value of the applied tensile stress)

<sup>3)</sup> No performance assessed

2) Calculation of effective displacement:

$$\delta_{V0} = \delta_{V0\text{-Factor}} \cdot V_{Ed}$$

$$\delta_{V\infty} = \delta_{V\infty\text{-Factor}} \cdot V_{Ed}$$

( $V_{Ed}$ : Design value of the applied shear force)

**Table C6.2: Displacements for fischer internal threaded anchors RG MI**

Internal threaded anchor RG MI	M8	M10	M12	M16	M20	
<b>Displacement-Factors for tension load<sup>1)</sup></b>						
<b>Uncracked concrete; Temperature range I, II</b>						
$\delta_{N0}$ -Factor	[mm/(N/mm <sup>2</sup> )]	0,10	0,11	0,12	0,13	0,14
$\delta_{N\infty}$ -Factor		0,13	0,14	0,15	0,16	0,18
<b>Displacement-Factors for shear load<sup>2)</sup></b>						
<b>Uncracked concrete; Temperature range I, II</b>						
$\delta_{V0}$ -Factor	[mm/kN]	0,12	0,12	0,12	0,12	0,12
$\delta_{V\infty}$ -Factor		0,14	0,14	0,14	0,14	0,14

1) Calculation of effective displacement:

$$\delta_{N0} = \delta_{N0\text{-Factor}} \cdot \tau_{Ed}$$

$$\delta_{N\infty} = \delta_{N\infty\text{-Factor}} \cdot \tau_{Ed}$$

( $\tau_{Ed}$ : Design value of the applied tensile stress)

2) Calculation of effective displacement:

$$\delta_{V0} = \delta_{V0\text{-Factor}} \cdot V_{Ed}$$

$$\delta_{V\infty} = \delta_{V\infty\text{-Factor}} \cdot V_{Ed}$$

( $V_{Ed}$ : Design value of the applied shear force)

fischer injection system FIS VL

**Performances**

Displacements for anchor rods and fischer internal threaded anchors RG MI

**Annex C 6**

Appendix 21/ 21